

STOVE BOARD ASSEMBLY

COMPATIBILITY: MSR XGK-EX stove*, 591ml and 887ml MSR fuel bottles

INCLUDES: Stove board, 3 x M4 bolts, wing nuts and split washers

You will need: drill and 4mm bit

* other stoves may be used by drilling matching 4mm holes in the base

1. Turn your board upside down and place bolts into the 3 holes (underside is soft foam, topside is hard board)
2. Turn the board over and place it on a firm surface

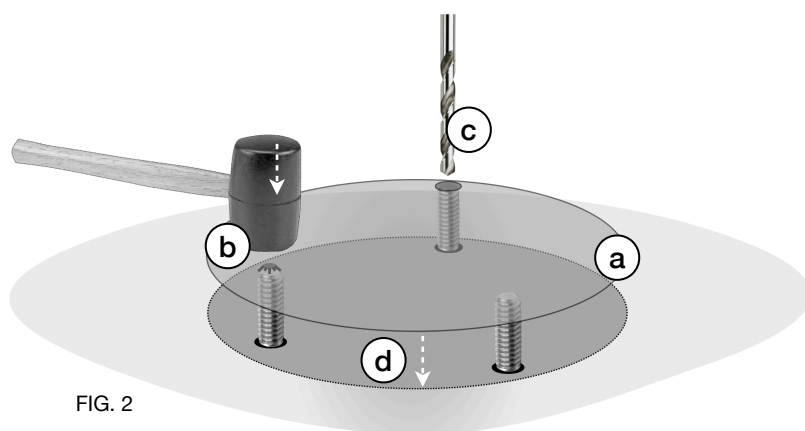
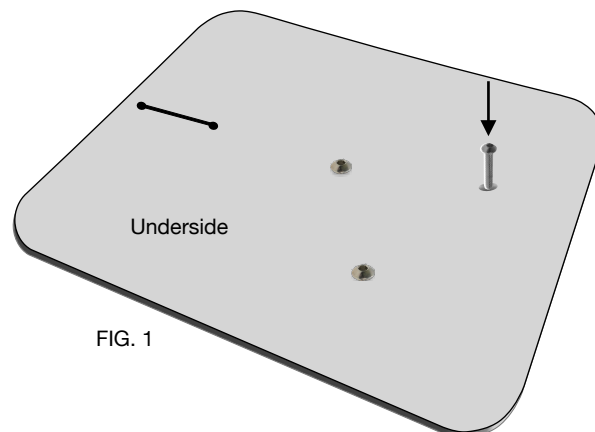

3. Centre the MSR circular heat reflector (provided with your stove) over the bolts (a)
4. Using a mallet, tap each bolt to mark bolt positions onto the reflector (b)
5. Drill 3 x 4mm holes into the circular reflector (c)
6. Thread reflector over bolts to sit flat on the board (d)

7. Place the feet of your MSR stove over the bolts ensuring fuel line is oriented as in Fig 4.
8. Centre the stove and secure each foot using split washers and wing nuts

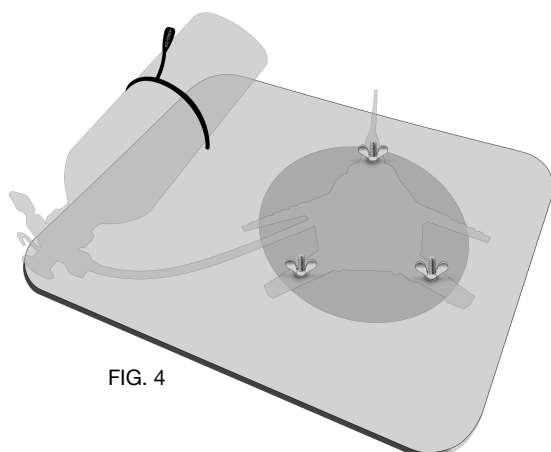
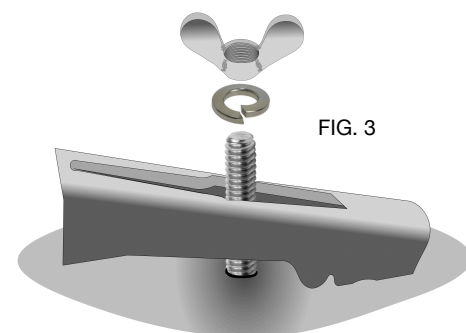

9. Secure your MSR fuel bottle to the stove fuel line
10. Slide the bottle under the shock cord
11. Your stove assembly is now secured to the board